

Data Reconciliation

Davide Manca

Lesson 6 of "Process Systems Engineering A" – Master Degree in Chemical Engineering – Politecnico di Milano



Hierarchical approach to process optimization

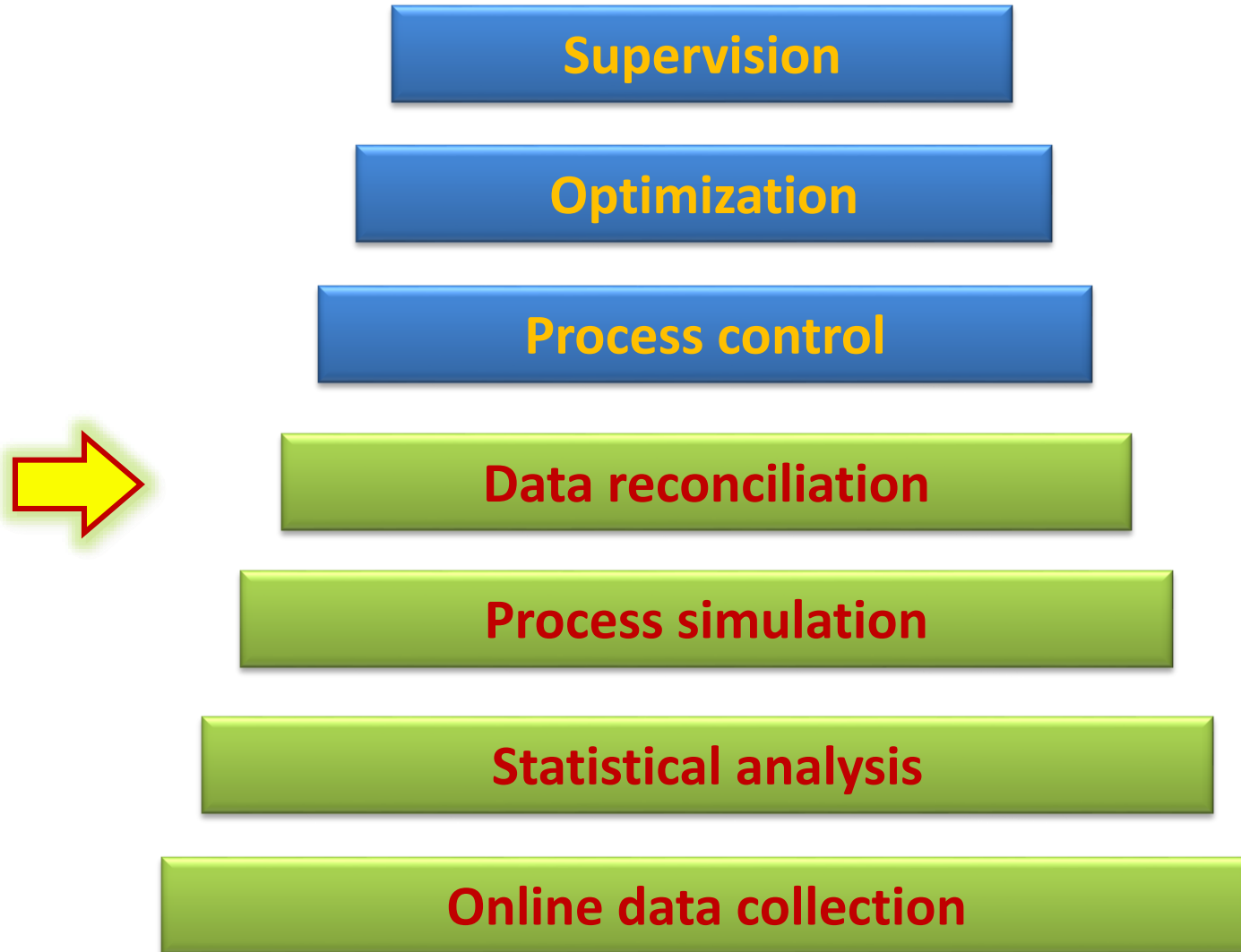

Process

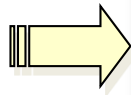
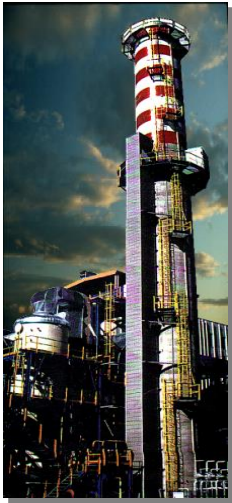

DCS

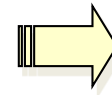

Supervisor system

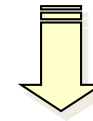

Data collection

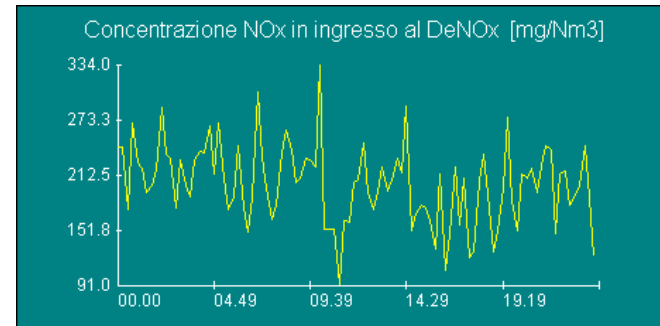

Statistical analysis

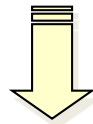
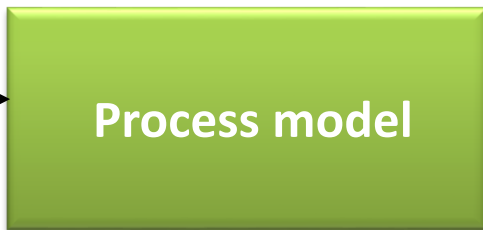
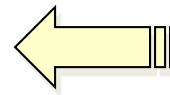
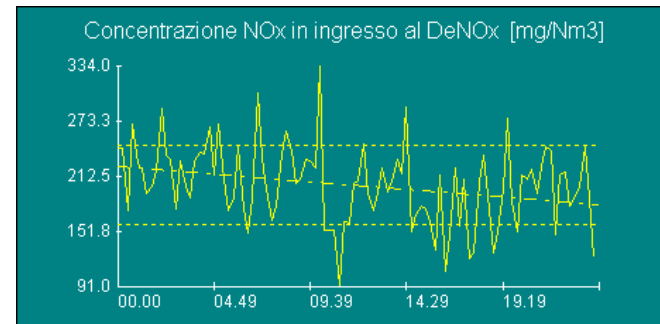

About data reconciliation...

□ Classical reconciliation of measures

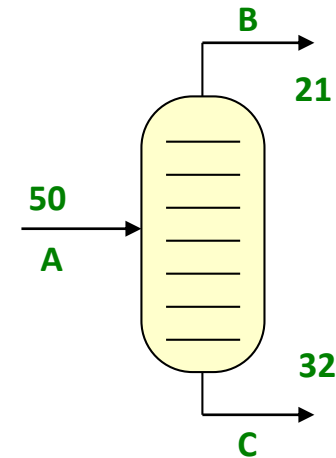

About data reconciliation...

- ❑ Classical reconciliation of measures

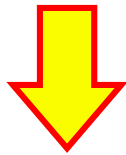

- ❑ **Gross error detection**

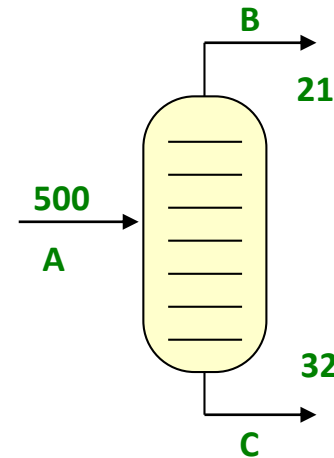
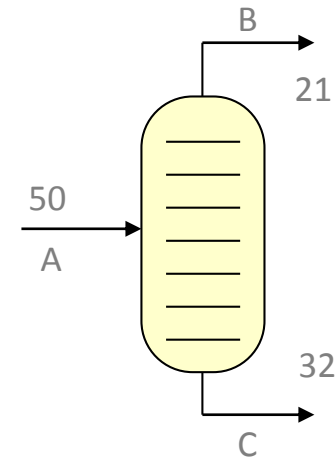

About data reconciliation...

□ Coaptation

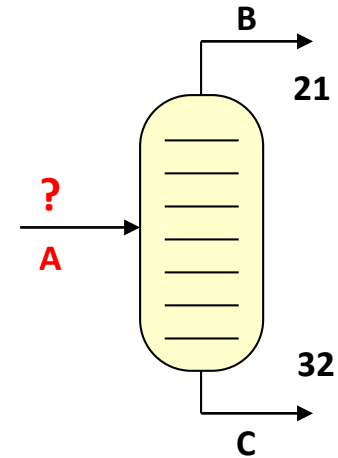

About data reconciliation...

□ Model identification

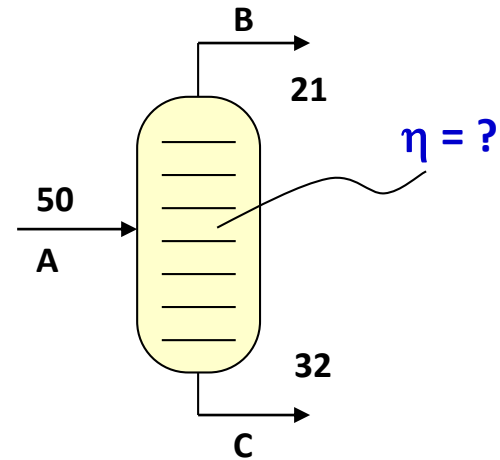

Introduction

- The **Data Reconciliation** methodology can be divided into **three distinct phases** (Romagnoli e Sanchez, 2000):
 - **Classification** of process variables and decomposition of the problem;
 - **Detection, identification** and **estimation** of gross errors;
 - **Estimation** of **process variables not measured** or not measurable.

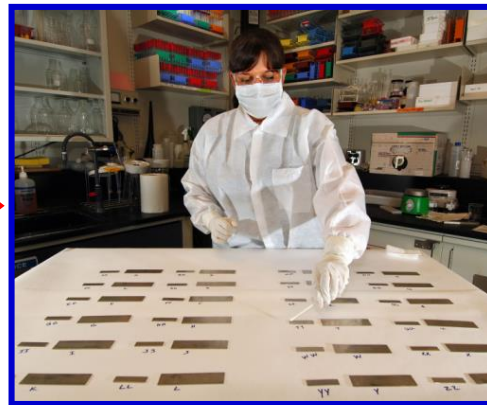
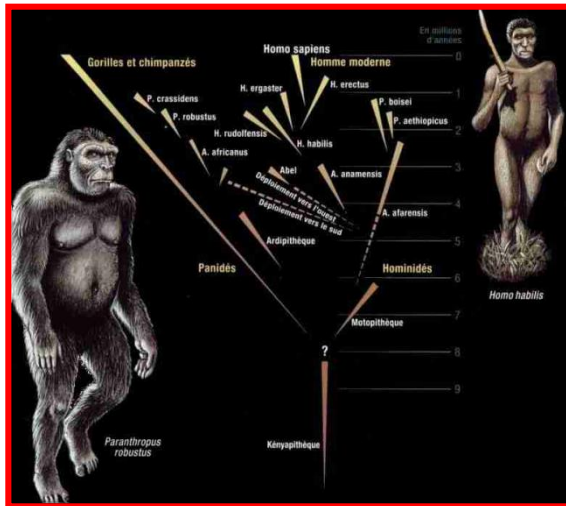

Measurement classification

- Because of costs, convenience, and technical reasons, **not all the process variables are measured**.
- By assuming that the process is working in steady-state conditions, some unmeasured variables can be **estimated** using other measured variables and calculations based on mass and energy balances.
- The estimation of **not measured variables** depends on the **process layout** and on the in-the-field **instrumentation**.
- In general, the process instrumentation is incomplete (it does not measure all the process variables).

The **unmeasured** variables can be divided into:

- **Predictable variables** (determinable)
- **Unpredictable variables** (undeterminable)



Measurement classification

- Furthermore, **measures** can be classified into:
 - **redundant**
 - **nonredundant**
- A measure is **redundant** if it remains **determinable** when the observation is removed.
- The classification of the variables is an essential tool to design and revamp monitoring systems.
- A **robust classification** of variables leads to **significant savings** linked to the selection of instrumentation for field installation.
- An incorrect classification of variables leads to the introduction of unnecessary instrumentation involving higher investment costs.

Measurement classification

- Once the variables are classified, we have a significant amount of information concerning the process topology.
- It is now possible to solve the following problems:
 - **Select the set of measured variables** which must be corrected (reconciled) in order to increase the accuracy of the measured and unmeasured process variables.
 - **Select the minimum number of measures** so that all the unmeasured variables can be determined.



Process model

- The **process model** is a mathematical formulation that describes its behaviour under either **STEADY STATE** or **DYNAMIC** conditions.
- The process model is used at several levels:
 - To **infer** unmeasurable parameters
 - To **reconcile** measures
 - To **identify** measures affected by **gross errors**
 - To determine the **optimal control** action
 - Model based control (for example: Model Predictive control)
 - Feedforward control
 - For **process optimization**
 - For **process supervision**
- The process can be described by either **linear** or **nonlinear models**: ARX, NARX, ARMAX, NARMAX, Laplace transforms, Regressions, Artificial neural networks (ANN), deterministic and phenomenological models (First Principles), ...



Redundancy

- Romagnoli and Sanchez (2000) define a **system** as being **redundant** when the whole collection of data/information available exceeds the minimum required amount for a univocal determination of the independent variables that describe the selected model.
- Since the data are obtained from process measurements affected by probabilistic fluctuations, **redundant data are generally inconsistent** thus every data subset provides different results from other subsets.
- In order to obtain a **consistent solution** to the problem of determining the measures, it is therefore necessary to introduce an **additional criterion**.



Redundancy

❑ Redundancy of the system

In case of Black Box approach we define the **redundancy** as the difference between the number of measured variables and the number of degrees of freedom:

$$\text{Redundancy} = \# \text{ measured variables} - \# \text{ dof} = NY - NPAR$$

The **system** describing numerically the reconciliation problem is **OVERDETERMINED**. There are more equations than unknowns.

$$\begin{cases} y_{exper}(1) - y_{calc}^1(x_1, x_2, \dots, x_{NPAR}) = 0 \\ y_{exper}(2) - y_{calc}^2(x_1, x_2, \dots, x_{NPAR}) = 0 \\ \dots \\ y_{exper}(NY) - y_{calc}^{NY}(x_1, x_2, \dots, x_{NPAR}) = 0 \end{cases}$$

The **overdetermination** of the system leads to the impossibility of completely satisfying it. Conversely, it is possible to minimize the sum of squares of the equations by solving a minimization problem with a non-linear regression in the parameters, \mathbf{x} .

Object function

- The reconciliation procedure has to **minimize** the following **objective function**:

$$\text{Min}_{\mathbf{x}} f = \sum_{i=1}^{NY} \frac{[y_{\text{exper}}(i) - y_i^{\text{calc}}(\mathbf{x})]^2}{s^2(i)}$$

By introducing the **incidence matrix** \mathbf{M}_I ,

it is possible to check if a *dof* does NOT affect any measure (column-wise) or if a measure is NOT affected by any *dof* (row-wise).

If two columns are linearly dependent then there is a high functional dependency between those degrees of freedom.

$$\mathbf{M}_I = \begin{bmatrix} \frac{\partial y_{\text{calc}}^1}{\partial x_1} & \frac{\partial y_{\text{calc}}^1}{\partial x_2} & \cdots & \frac{\partial y_{\text{calc}}^1}{\partial x_{NPAR}} \\ \frac{\partial y_{\text{calc}}^2}{\partial x_1} & \frac{\partial y_{\text{calc}}^2}{\partial x_2} & \cdots & \frac{\partial y_{\text{calc}}^2}{\partial x_{NPAR}} \\ \cdots & \cdots & \cdots & \cdots \\ \frac{\partial y_{\text{calc}}^{NY}}{\partial x_1} & \frac{\partial y_{\text{calc}}^{NY}}{\partial x_2} & \cdots & \frac{\partial y_{\text{calc}}^{NY}}{\partial x_{NPAR}} \end{bmatrix}$$

Solution of the reconciliation problem

- The Reconciliation **problem** can be **solved** if we have:
 - **Positive redundancy**
 - **Independent degrees of freedom**
 - A **robust numerical algorithm** especially if we work online

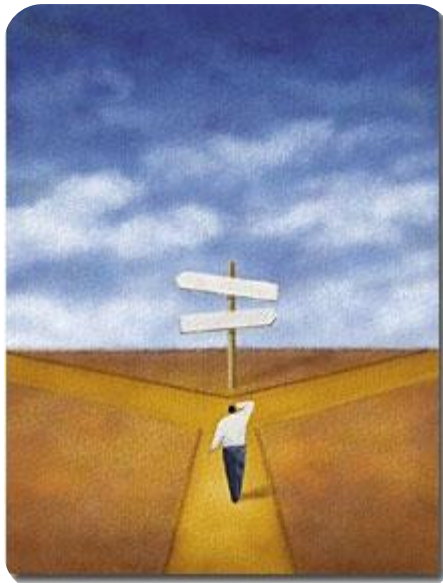

Solution of the reconciliation problem

- The **basic assumptions** are as follows:
 1. The **process model** is able to properly represent the system under consideration (model validation);
 2. The **measures** are subject to an ε error that is **normally distributed** with average equal to zero and variance σ known (or that can be computed);
 3. The measures come from a **stationary process**.
- The failure of Reconciliation (once hypothesis **1** is verified) is due to points **2** and **3**. There may be measures affected by **gross error** that have a non-zero averaged error ε :

$$E(\varepsilon) = \int_{-\infty}^{+\infty} \varepsilon p(\varepsilon) d\varepsilon = \int_{-\infty}^{+\infty} \frac{\varepsilon}{\sqrt{2\pi\sigma^2}} \exp\left(-\frac{\varepsilon^2}{2\sigma^2}\right) d\varepsilon \neq 0$$

- Possible causes of gross errors are: unreliable instruments, non-homogeneous conditions around the instrument, process instability, accidents, transcription errors, communication failures, non-stationary conditions.

Statistical analysis

- To perform the Data Reconciliation procedure we must start from the averaged measured values (measured in the field at a given time when the process is mildly stationary).
- At this regard, we have the expected value $\mu(i)$ and variance $\sigma(i)$ of the measure.
- It is possible to distinguish between efficient and robust estimators:

- **ROBUST estimators**

- For $\mu(i)$ we use the **Median**: it is the central value of the population in ascending order. In the case of an even number of terms we do the arithmetic mean of the two central values.
- For $\sigma(i)$ we use the **MAD** (Median Absolute Deviation)
$$\text{MAD}(i) = 1.4826 * \text{Median}(|y_{\text{exper}}(i,k) - \text{Median}(y_{\text{exper}}(i,k))|)$$

- **EFFICIENT estimators**

- **Arithmetic mean**: $y_s(i) = \sum_{k=1}^{NS} y_{\text{exper}}(i,k) / NS$
- **Standard deviation** or mean square deviation:
$$\sigma(i) = \sqrt{\sum_{k=1}^{NS} \frac{[y_{\text{exper}}(i,k) - y_s(i)]^2}{NS - 1}}$$

Model identification

- Once we have defined **NY = number of measures** and **NPAR = number of degrees of freedom** (parameters) it is possible to distinguish the following cases:
- **NPAR > NY (NEGATIVE redundancy)**

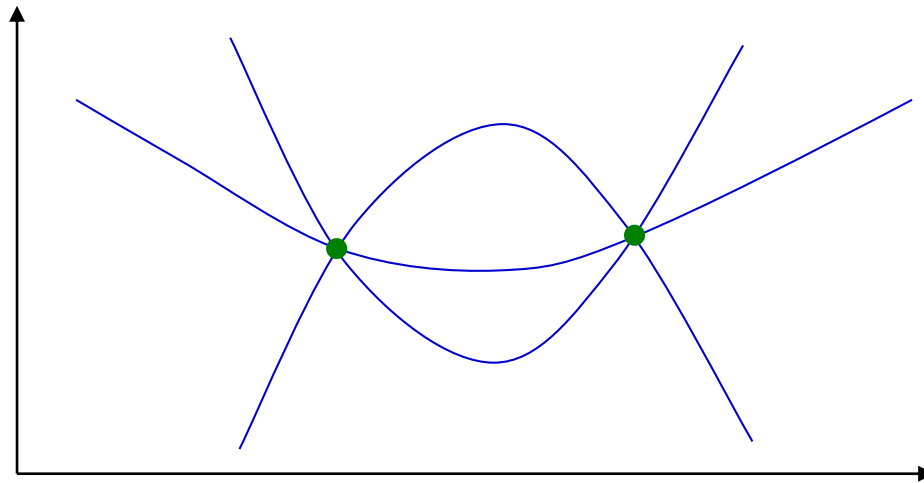

For instance: the proposed model $y = ax^2 + bx + c$ comprises three parameters (NPAR = 3) whilst the experimental points are just two. There is an infinite number of parabolas that match exactly the experimental data. It is not possible to identify any Gross Errors.

Model identification

- **NPAR = NY (NO redundancy)**

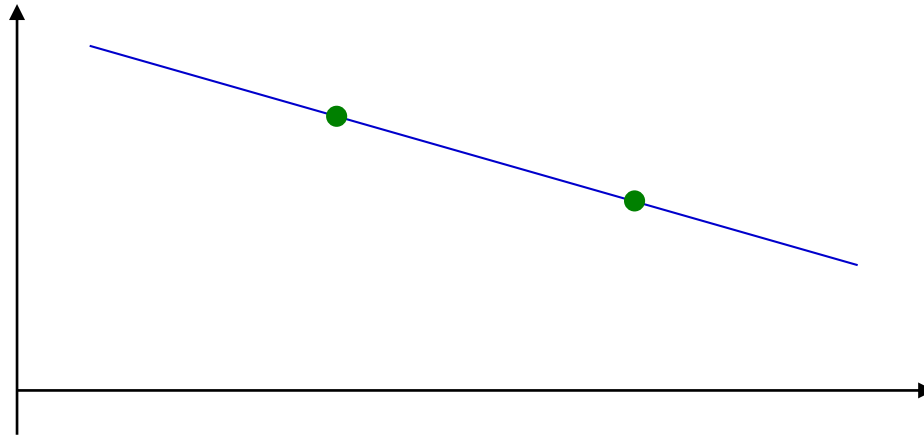

In this case, there is only one curve passing through the NY points. It is worth observing that, in this case, the model is a straight line ($y = ax + b$) depending on two parameters.

We have: $NPAR = 2$ and $NY = 2$. The redundancy is zero and it is NOT possible to detect any Gross Errors.

Model identification

- **NPAR < NY (POSITIVE redundancy)**

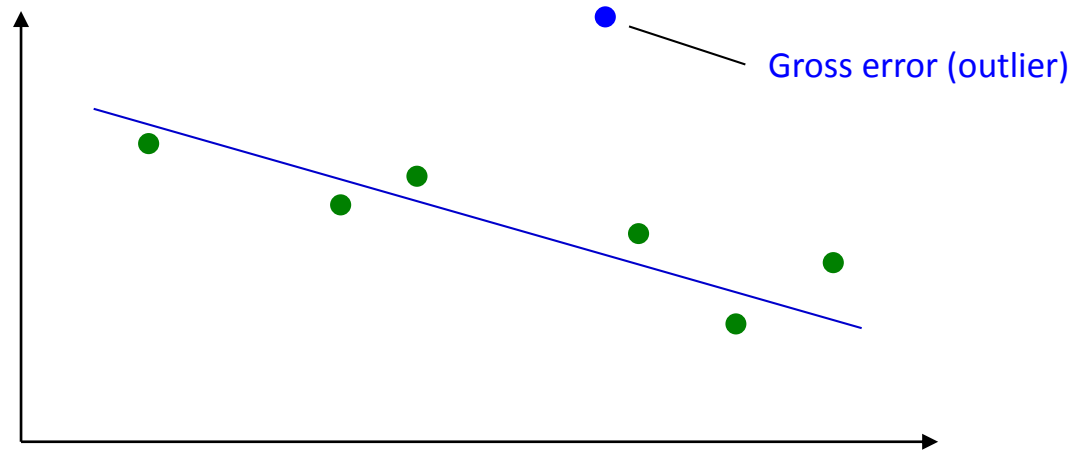

In this case, the proposed model is still a straight line ($NPAR = 2$) while the number of experimental points is seven: $NY = 7$. There is NOT a model that simultaneously satisfies all the experimental data. It is then necessary/advisable to minimize the error by minimizing the distance between the model and the measured data.

We can also detect NGE potential gross errors: $NGE = NY - NPAR = R = \text{Redundancy}$

N.B.: if we identify a gross error it is possible to eliminate it or compensate it with the value that has been just reconciled. In this case we do not decrease the redundancy.

Case-study

On-line data reconciliation of an incineration plant



Case study: incineration plant

Waste to energy plant with DeNOx catalytic section

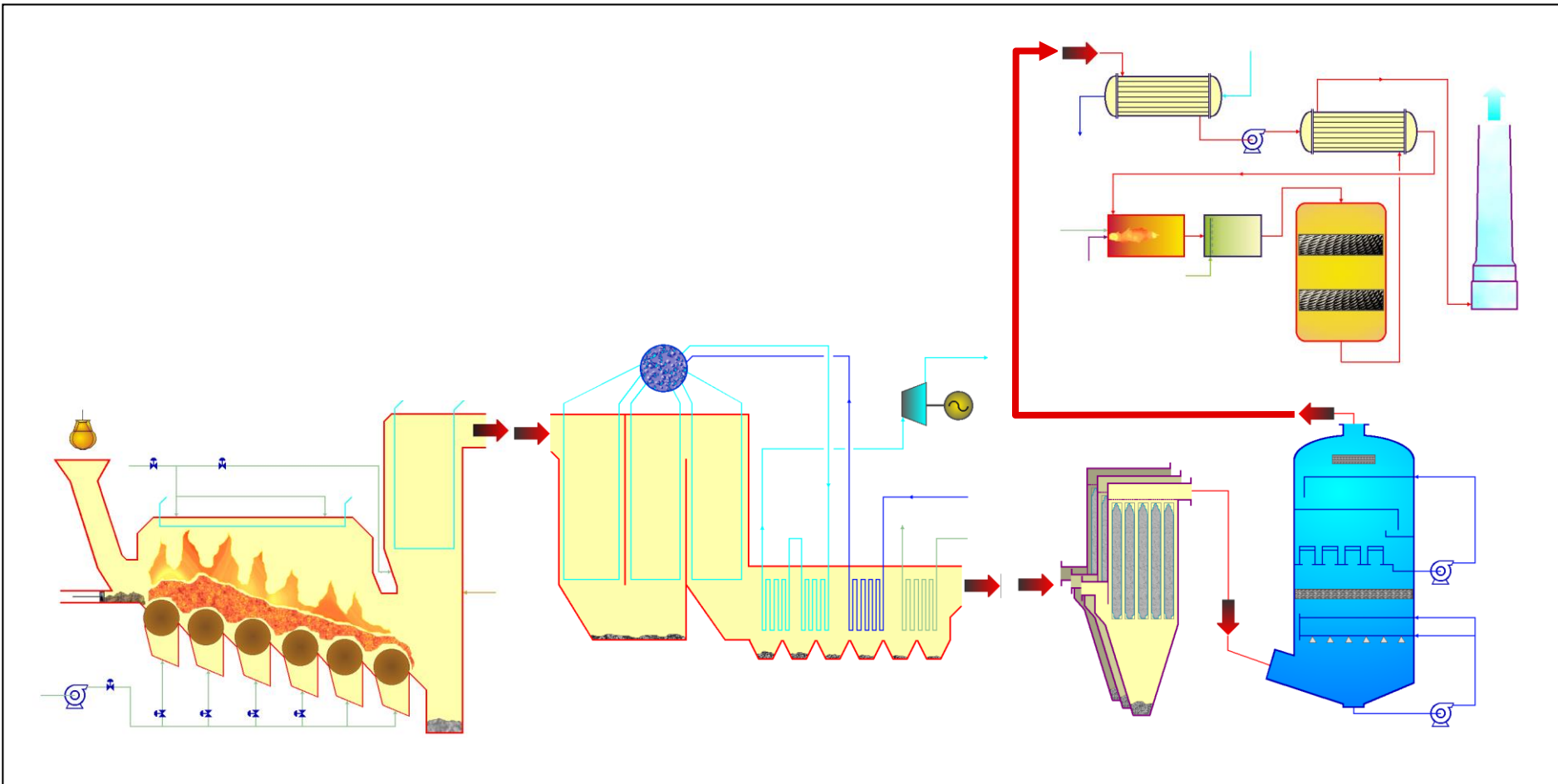

Case study: incineration plant

- **Specifications required**

- Evaluate the **consistent value** of the **measurements** from the field
- Identify measurements affected by gross error
- Real-time knowledge of the characteristics of the incoming waste in terms of **elemental composition** and **heat of combustion**
- Estimation of the inlet streams unmeasurable or not available:
 - **Air leakages**
 - **Methane flowrate** in the postcombustion chamber
- Evaluation of the **operating parameters**:
 - Bag filter efficiency
 - Catalyst efficiency
 - Heat exchangers fouling factor



Case study: incineration plant

□ Problem definition

Objective function:

$$\text{Min}_{\mathbf{x}} f = \sum_{i=1}^{NY} \frac{[y_{\text{exper}}(i) - y_i^{\text{calc}}(\mathbf{x})]^2}{s^2(i)}$$

Measures to be reconciled: 24

T gas postcomb.

T out gas radiative zone

T out gas preheater

Gas out washing column

T gas stack

NOx entering DeNOx

HCl to the stack

Soot to the stack

CO out postcomb.

T out gas superheater

T air combustion

T out gas heater

T in gas DeNOx

NOx exiting DeNOx

SO2 to the stack

O2 to the stack

O2 out postcomb.

T out gas economizer

Gas entering washing column

Tout gas heat exchanger gas-gas

T out gas DeNOx

Ammonia flow rate

CO to the stack

Steam flowrate

Degrees of freedom (parameters of reconciliation): 23

Waste flow rate

S fraction in the waste

Kiln air leakage

Losses in the boiler

Corr. fact. economiz.

Acid wash efficiency

Corr. fact. exch. gas-gas

Catalyst efficiency DeNOx

Ash fraction in the waste

N fraction in the waste

Bypass gas fraction in the furnace

Corr. heat exch. coeff. rad. zone

Corr. fact. Preheater

Basic wash efficiency

Preheater air flow rate

Air leakages after postcombust.

Cl fraction in the waste

C fraction in the waste

Methane flow rate afterburner

Corr. heat exch. coeff. superheater

Bag filter efficiency

Corr. fact. Steam heater

Methane flow rate burner DeNOx



Case study: incineration plant

- **Problem solution**

- We need a nonlinear regression routine to minimize the objective function.
- We must have a detailed model of the process that simulates the measurements (*i.e.* calculates the reconciled values of the acquired measurements) whenever the regression routine suggests a new vector of degrees of freedom.
- If the reconciliation procedure is NOT able to minimize the objective function to the required precision it means that the material, energy, and momentum balances describing the process “do not close”. In this case we can assume the presence of a gross error and remove the measure respect to which there is the larger deviation (or better replace the measured value with the estimated one). The procedure continues until we reach the required accuracy. If the assumed replaced measurement affected by gross error does NOT make the procedure successful, we reintroduce the original removed measure and eliminate the next one featuring the greatest deviation. In this case study the redundancy is equal to one, consequently it is possible to identify just one gross error.



Case study: incineration plant

□ The results...

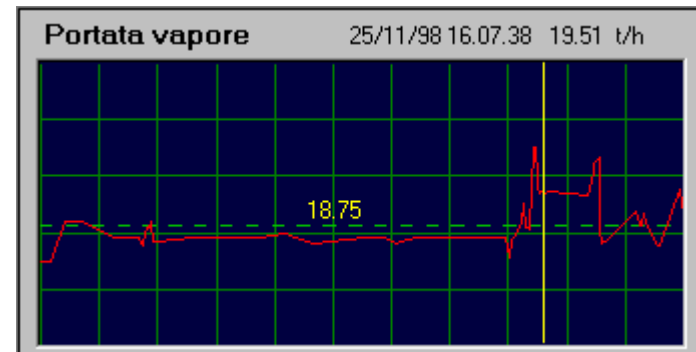
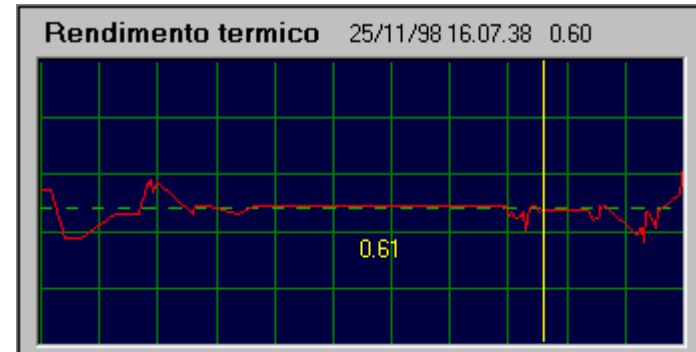
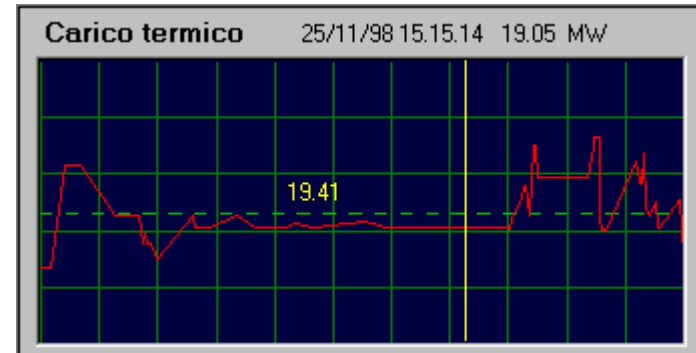
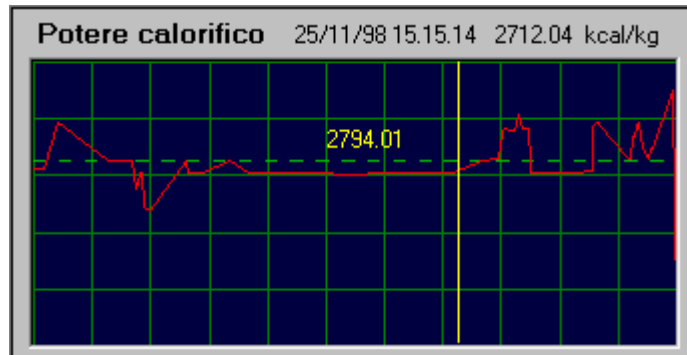
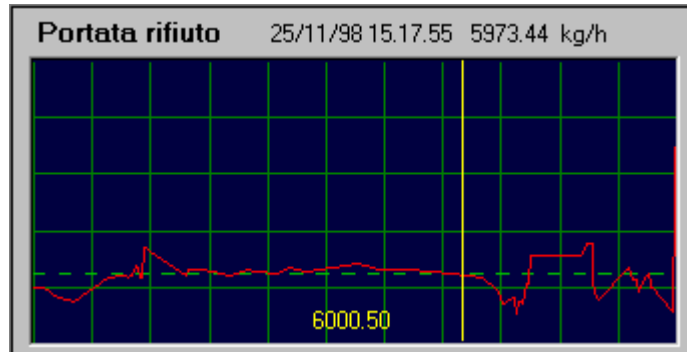

Case study: incineration plant

□ The results...

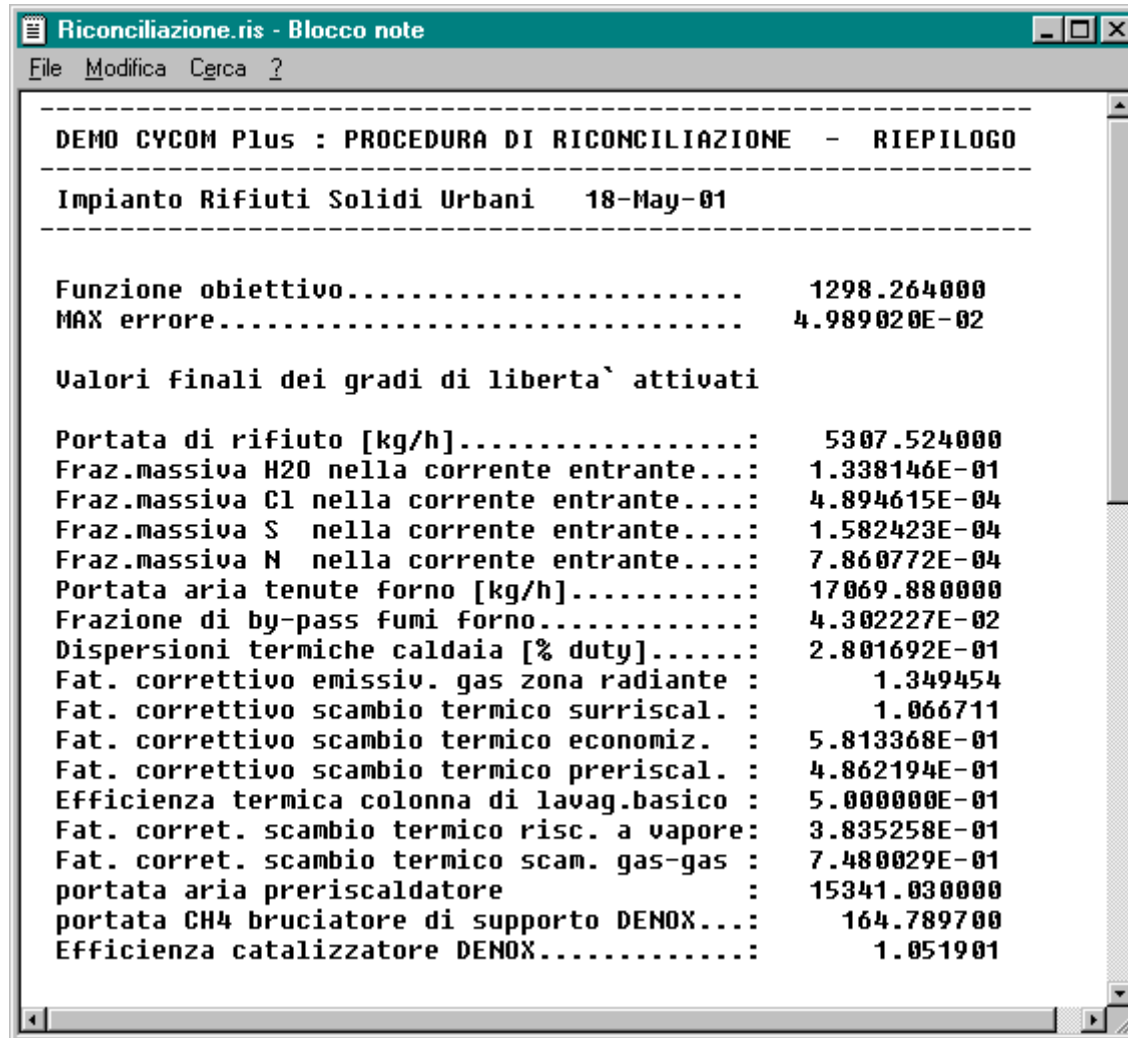

```
Riconciliazione.ris - Blocco note
File Modifica Cerca ?

-----
DEMO CYCOM Plus : PROCEDURA DI RICONCILIAZIONE - RIEPILOGO
-----
Impianto Rifiuti Solidi Urbani 18-May-01
-----

Funzione obiettivo..... 1298.264000
MAX errore..... 4.989020E-02

Valori finali dei gradi di liberta` attivati

Portata di rifiuto [kg/h].....: 5307.524000
Fraz.massiva H2O nella corrente entrante...: 1.338146E-01
Fraz.massiva Cl nella corrente entrante....: 4.894615E-04
Fraz.massiva S nella corrente entrante....: 1.582423E-04
Fraz.massiva N nella corrente entrante....: 7.860772E-04
Portata aria tenute forno [kg/h].....: 17069.880000
Frazione di by-pass fumi forno.....: 4.302227E-02
Dispersioni termiche caldaia [% duty].....: 2.801692E-01
Fat. correttivo emissiv. gas zona radiante : 1.349454
Fat. correttivo scambio termico surriscal. : 1.066711
Fat. correttivo scambio termico economiz. : 5.813368E-01
Fat. correttivo scambio termico preriscal. : 4.862194E-01
Efficienza termica colonna di lavag.basico : 5.000000E-01
Fat. corret. scambio termico risc. a vapore: 3.835258E-01
Fat. corret. scambio termico scam. gas-gas : 7.480029E-01
portata aria preriscaldatore : 15341.030000
portata CH4 bruciatore di supporto DENOX...: 164.789700
Efficienza catalizzatore DENOX.....: 1.051901
```

Case study: incineration plant

□ The results...

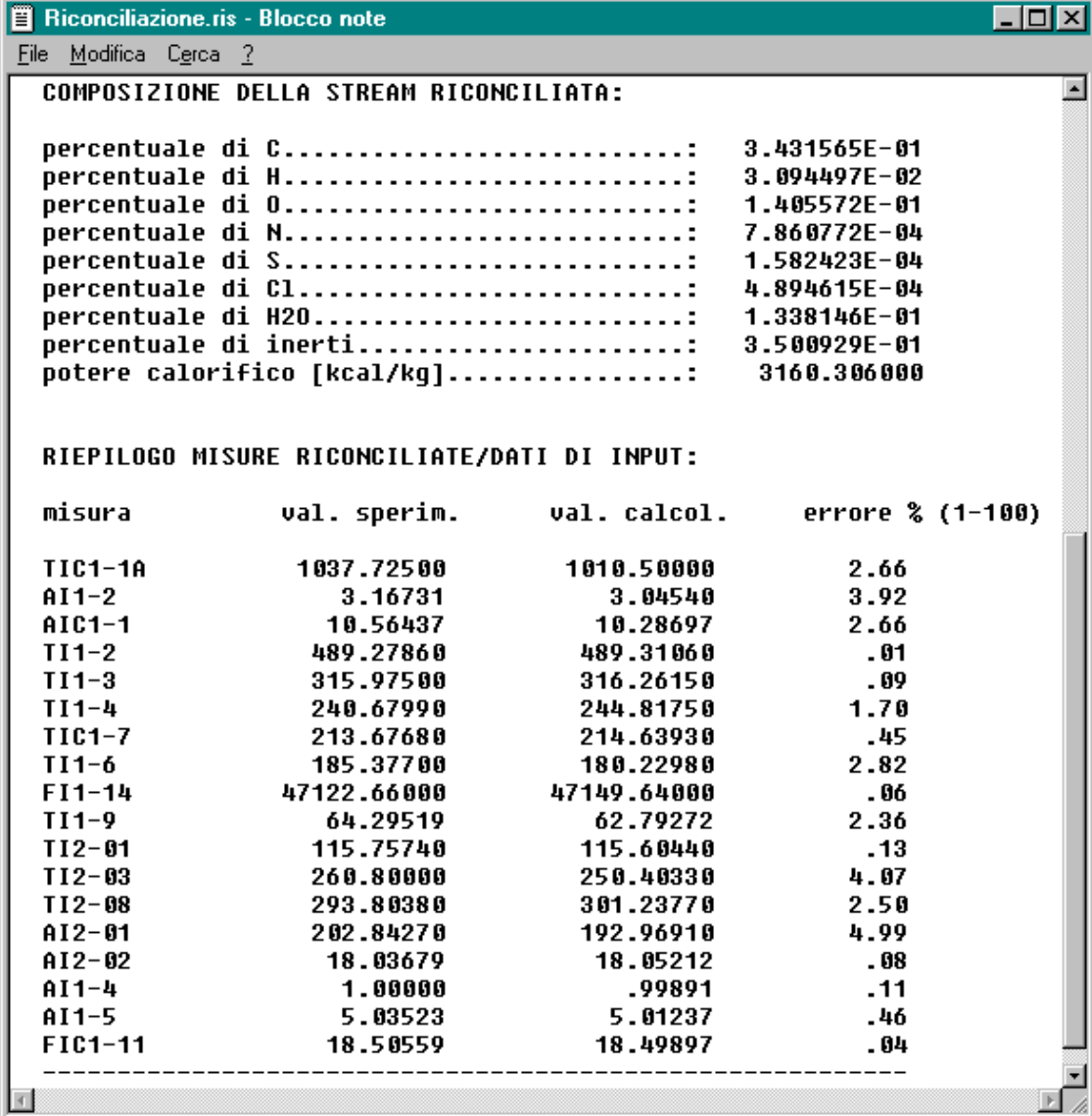

COMPOSIZIONE DELLA STREAM RICONCILIATA:

percentuale di C.....	3.431565E-01
percentuale di H.....	3.094497E-02
percentuale di O.....	1.405572E-01
percentuale di N.....	7.860772E-04
percentuale di S.....	1.582423E-04
percentuale di Cl.....	4.894615E-04
percentuale di H2O.....	1.338146E-01
percentuale di inerti.....	3.500929E-01
potere calorifico [kcal/kg].....	3160.306000

RIEPILOGO MISURE RICONCILIATE/DATI DI INPUT:

misura	val. sperim.	val. calcol.	errore % (1-100)
TIC1-1A	1037.72500	1010.50000	2.66
AI1-2	3.16731	3.04540	3.92
AIC1-1	10.56437	10.28697	2.66
TI1-2	489.27860	489.31060	.01
TI1-3	315.97500	316.26150	.09
TI1-4	240.67990	244.81750	1.70
TIC1-7	213.67680	214.63930	.45
TI1-6	185.37700	180.22980	2.82
FI1-14	47122.66000	47149.64000	.06
TI1-9	64.29519	62.79272	2.36
TI2-01	115.75740	115.60440	.13
TI2-03	260.80000	250.40330	4.07
TI2-08	293.80380	301.23770	2.50
AI2-01	202.84270	192.96910	4.99
AI2-02	18.03679	18.05212	.08
AI1-4	1.00000	.99891	.11
AI1-5	5.03523	5.01237	.46
FIC1-11	18.50559	18.49897	.04

From data reconciliation to on-line optimization

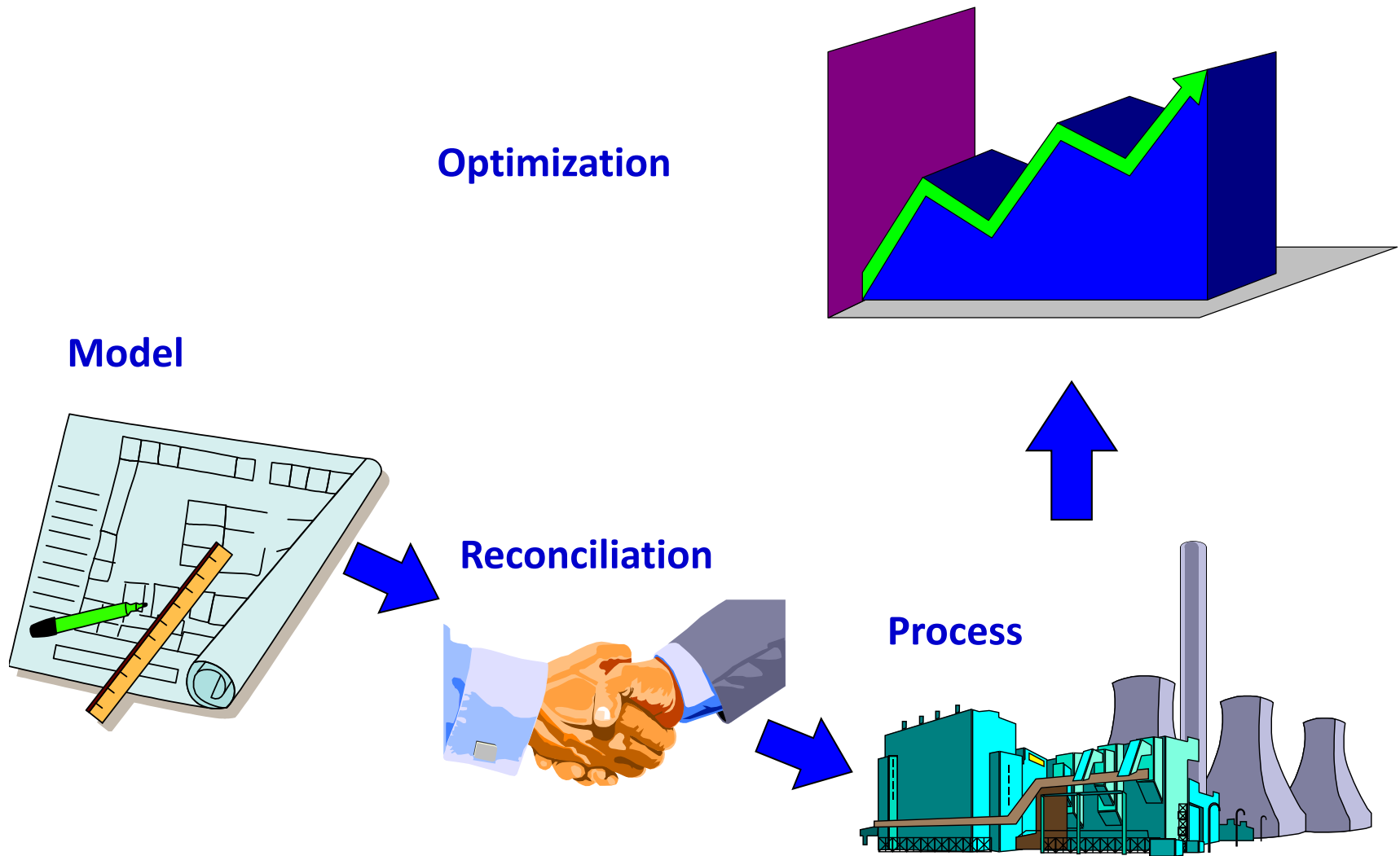

References

- Biegler L.T., J.J. Damiano, G.E. Blau, “Non linear parameter estimation: a Case-study comparison”, *AIChE J.*, 32, 29-43, (1986)
- Crowe C.M., “Reconciliation of process flow rates by matrix projection. Part II: the non linear case”, *AIChE J.*, 44, 2909-2917, (1986)
- Crowe C.M., “Data reconciliation – Progress and challenges”, *J. Proc. Control*, 6, 89-98, (1996)
- Kretsovalis A., R.S.H. Mah, “Observability and redundancy classification in generalized process networks. I: Theorems”, *Comput. Chem. Eng.*, 12, 671-687, (1988a)
- Kretsovalis A., R.S.H. Mah, “Observability and redundancy classification in generalized process networks. II: Algorithms”, *Comput. Chem. Eng.*, 12, 689-703, (1988b)
- Mah R.S.H., “Chemical process structures and Information flows”, *Chem. Eng. Ser. Butterworth*, Boston, (1990)
- Mah R.S.H., G. Stanley, D. Downing, “Reconciliation and rectification of process flows and inventory data”, *Ind. Eng. Chem. Process Des. Dev.*, 15, 175-183, (1976)
- Manca D., M. Rovaglio, S. Pierucci, T. Faravelli, “Reconciliation, Optimization and Supervisory Control of Crude Oil Distillation Systems”, *The First Conference on Chemical and Process Engineering*, Firenze, 255-259, (1993)
- Manca D., M. Rovaglio, “Numerical Modeling of a Discontinuous Incineration Process With On Line Validation”, *Ind. Eng. Chem. Res.*, 44, 3159-3177, (2005)



References

- **Narasimhan S., C. Jordache, “Data Reconciliation and Gross Error Detection : An Intelligent Use of Process Data”, Gulf Professional Publishing, Houston, (2000)**
- *Rovaglio M., D. Manca, M. Mariano, G. Nini, R. Gani, “Data Reconciliation and Process Optimization for Hazardous Waste Incineration Plants”, Proceedings of "PSE: Process Systems Engineering", pp. 613-621, ISBN 89 950005-1-1, Kyongju Korea, (1994)*
- *Rovaglio M., D. Manca, “Reconciliation and Model Identification as a First Step for On Line Optimization of Incineration Processes”, Proceedings of International Conference on Incineration & Thermal Treatment Technologies, IT3, S. Francisco, USA, pp. 587 596, (1997)*
- **Romagnoli J.A., M.C. Sanchez, Data Processing and Reconciliation for Chemical Process Operations, Academic press, New York, 2000**
- Stanley G., R.S.H. Mah, “Observability and redundancy in process data estimation”, Chem. Eng. Sci., 36, 259-272, (1981a)
- Stanley G., R.S.H. Mah, “Observability and redundancy classification in process networks – Theorems and algorithms”, Chem. Eng. Sci., 36, 1941-1954, (1981b)
- Tjoa I. B., L.T. Biegler, “Simultaneous strategies for data reconciliation and gross error detection of nonlinear systems”, Comp. and Chem. Engineering, 15, 679–690, (1991)
- Vaclavek V., “Studies on system engineering. III. Optimal choice of the balance measurement in complicated chemical engineering systems”, Chem. Eng. Sci., 24, 947-955, (1969)

