

# Process Systems Engineering

Prof. Davide Manca

## Case studies with the process simulator: UNISIM

### Example 1 - Flash

#### Case study 1.1

Thermodynamic Equation of State: SRK

Data:

- Liquid feed
  - Flow, kmol/h 300.
  - Temperature, K 343.
  - Pressure, kPa 1000.
  - Molar fractions:
    - 1 - BENZENE 0.1082
    - 2 - BUTANO 0.3243
    - 3 - 1-BUTENE 0.1351
    - 4 - 1,3-BUTADIENE 0.4324
- Operative conditions
  - Duty, 1E+6 kJ/h 2.
  - Pressure drop, kPa 400.

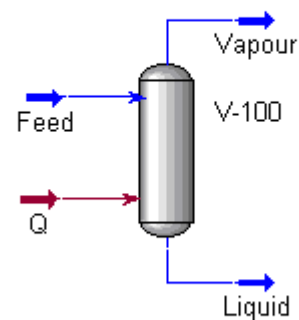

#### Case study 1.2

Thermodynamic Equation of State: SRK

Data:

- Liquid feed
  - Flow, kmol/h 300.
  - Temperature, K 343.
  - Pressure, kPa 1000.
  - Molar fractions: (see case study 1.1)
    - 1 - BENZENE 0.1082
    - 2 - BUTANO 0.3243
    - 3 - 1-BUTENE 0.1351
    - 4 - 1,3-BUTADIENE 0.4324
- Flash (Adiabatic)
  - Duty, 1E+6 kJ/h 0.
  - Pressure drops, kPa 0.
- Valve
  - Pressure drops, kPa 600.
- Heat exchanger (Cold Side)
  - Duty, 1E+6 kJ/h 2.
  - Pressure drops, kPa 0.
- Pump
  - Prevalence, kPa 500.

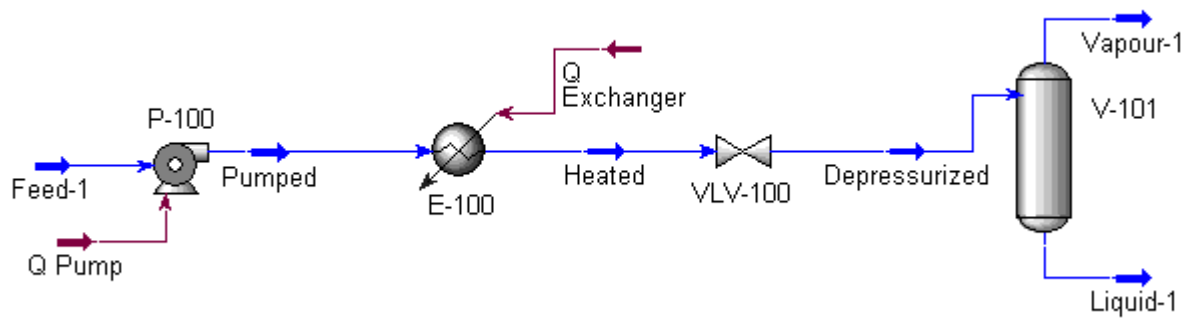

## Example 2 – Ammonia production

Thermodynamic Equation of State: Grayson-Streed

### Case study 2.1

Data:

- Feed
  - Flow, kmol/h 1000.
  - Temperature, K 673.
  - Pressure, kPa 50000.
  - Molar fractions:
 

1 - NH <sub>3</sub>	0.0000
2 - H <sub>2</sub>	0.7143
3 - N <sub>2</sub>	0.2381
4 - CH <sub>4</sub>	0.0476
- Reactor (adiabatic)
  - Reaction Set : Ammonia
  - Reaction : Synthesis  $N_2+3H_2=2NH_3$
  - Reaction phase: Overall
- Conversion 0.1
- Pressure drops, kPa 5000.
- Duty, 1E+6 kJ/h 0.
- Heat exchanger (Hot side)
  - Outlet temperature, K 260.
  - Pressure drops, kPa 0.
- Separator (adiabatic)
  - Duty, 1E+6 kJ/h 0.
  - Pressure drops, kPa 0.

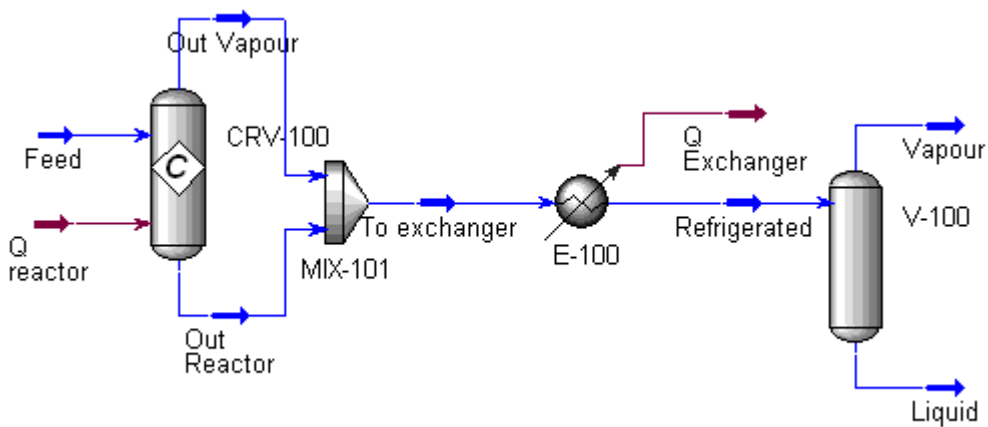

### Case study 2.2

Data:

- Splitter (Tee)  
Purge/(Splitter feed) 0.1
- Compressor  
Outlet pressure, kPa 50000.
- Heat exchanger (Cold Side)  
Outlet temperature, K 673.

